

Oil-injected screw air end

GCU55

power range [kw]	55
volum flow max [m ³ /min]	8.6
Pressure max [Barg]	12
Male rotor speed max [rpm]	6500
Lobe combination	5/6

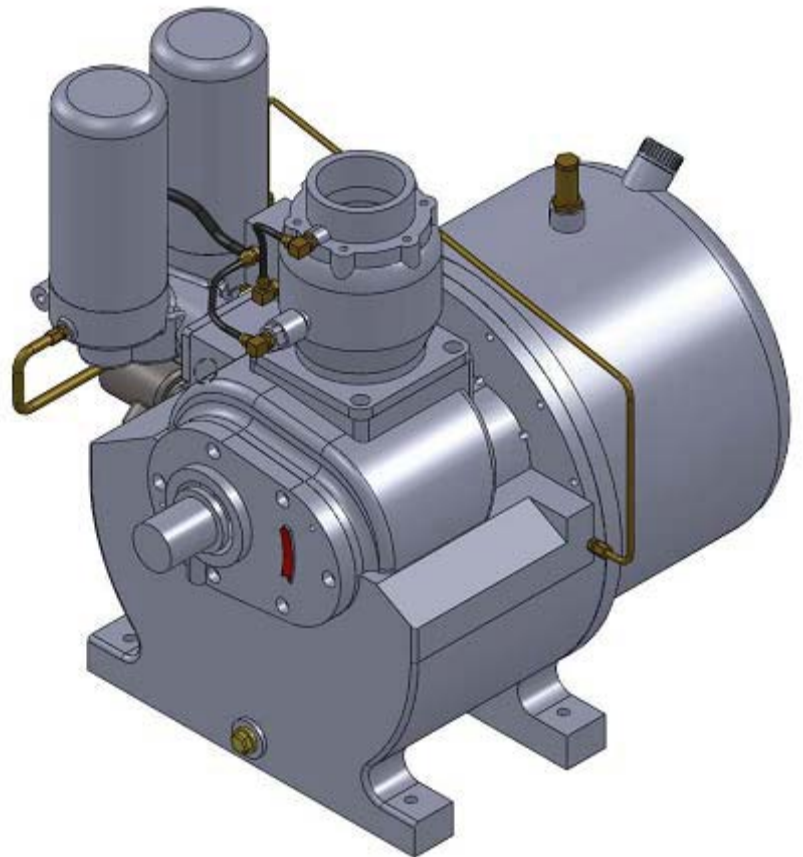

Performance data

Performance statements according to ISO 1217

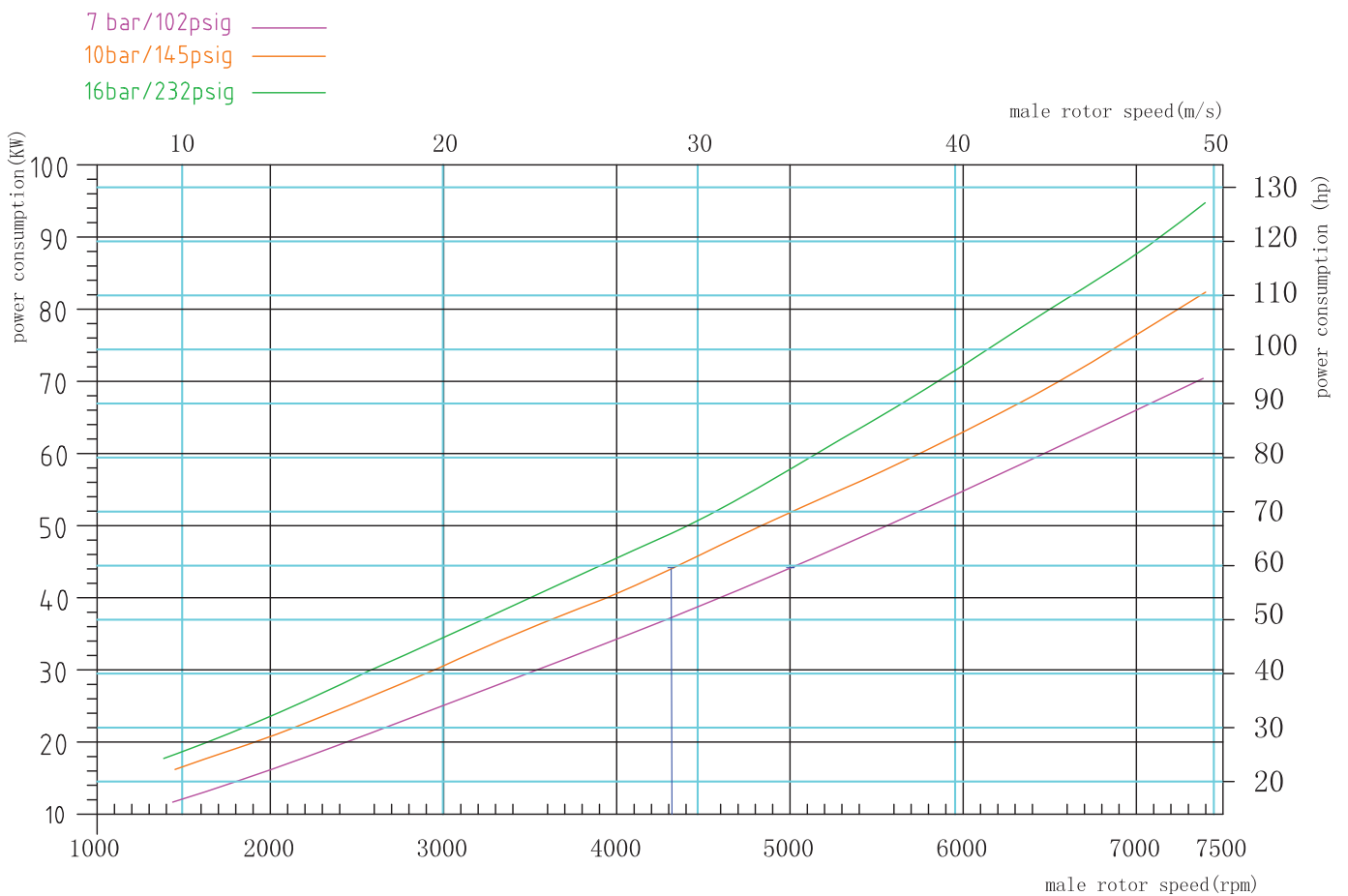
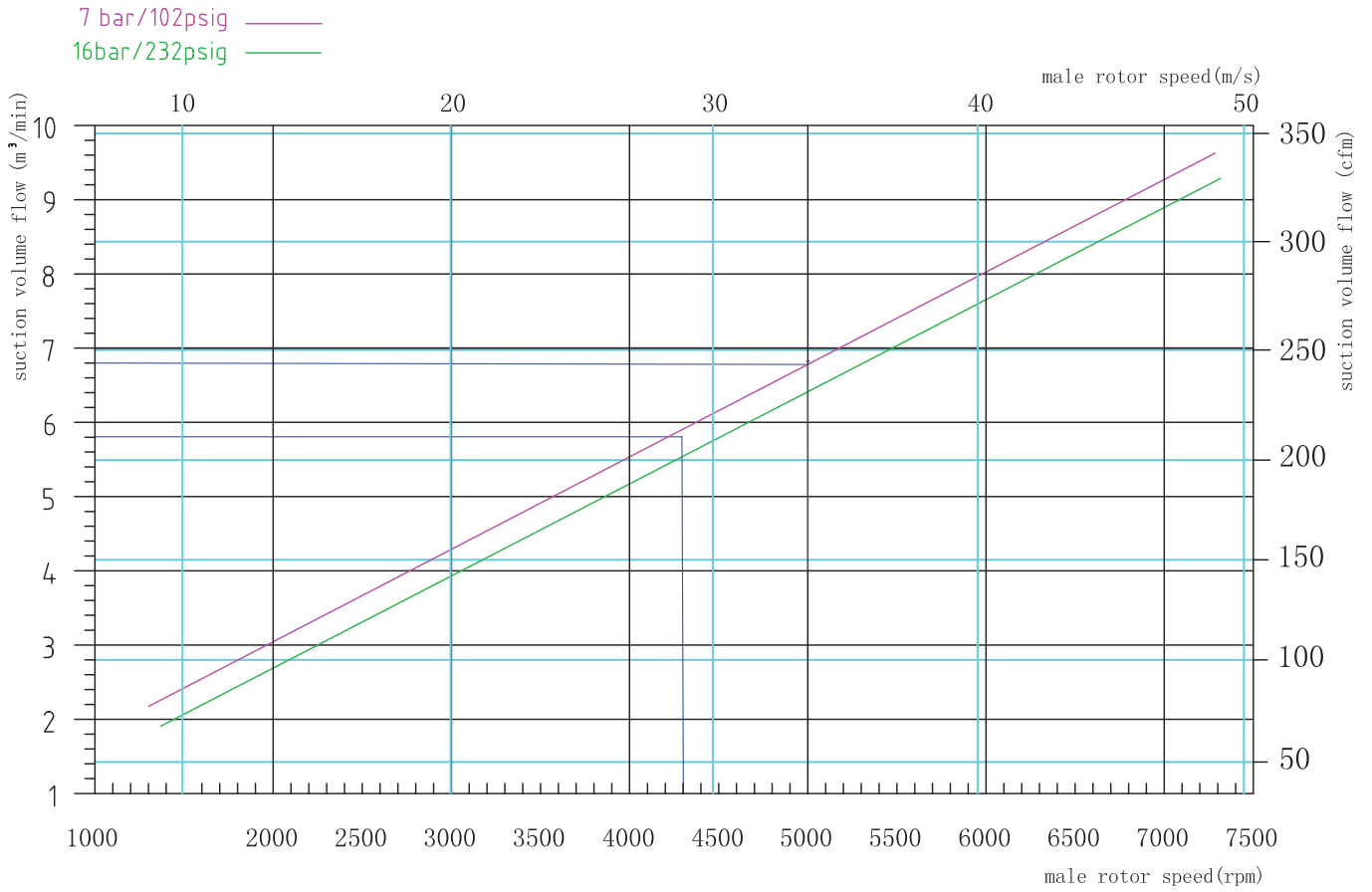

Oil-injected screw air end

GCU55

Installation drawing [mm]

Weight [kg] 190

