

Oil-injected screw air end

# GCU30

<b>power range</b> [kw]	30
<b>volum flow max</b> [m <sup>3</sup> /min]	4.3
<b>Pressure max</b> [Barg]	12
<b>Male rotor speed max</b> [rpm]	7200
<b>Lobe combination</b>	4/6

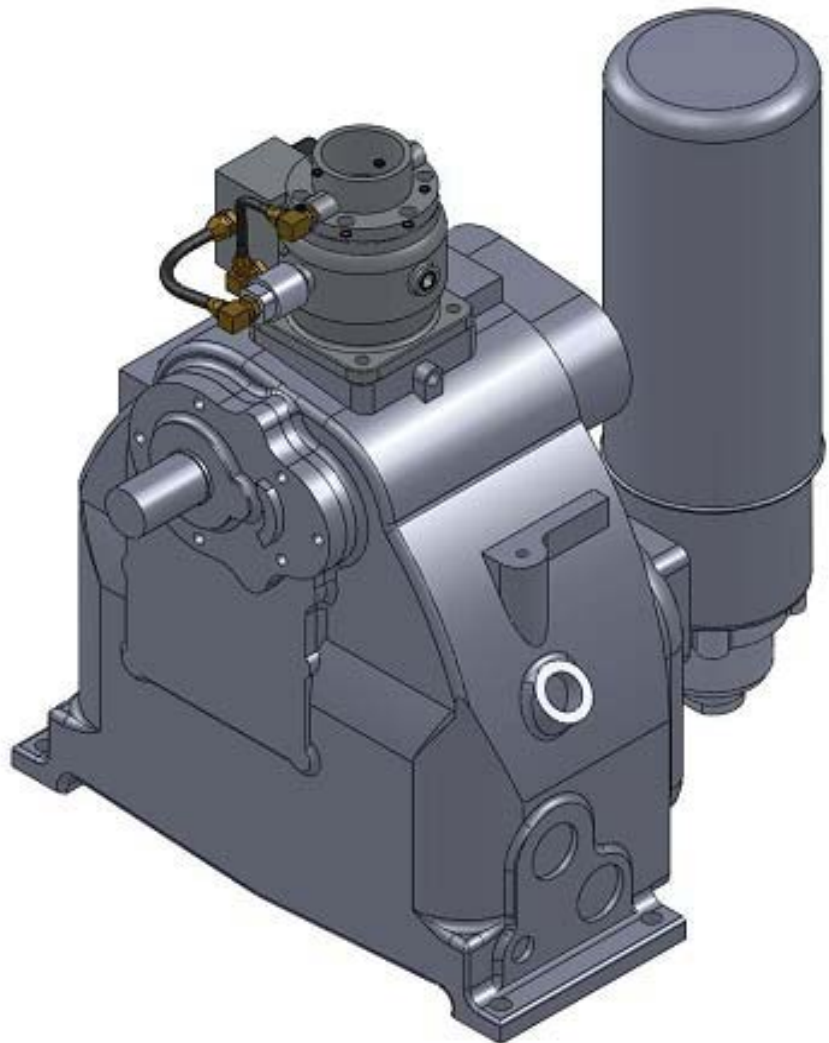

# Performance data

## Performance statements according to ISO 1217

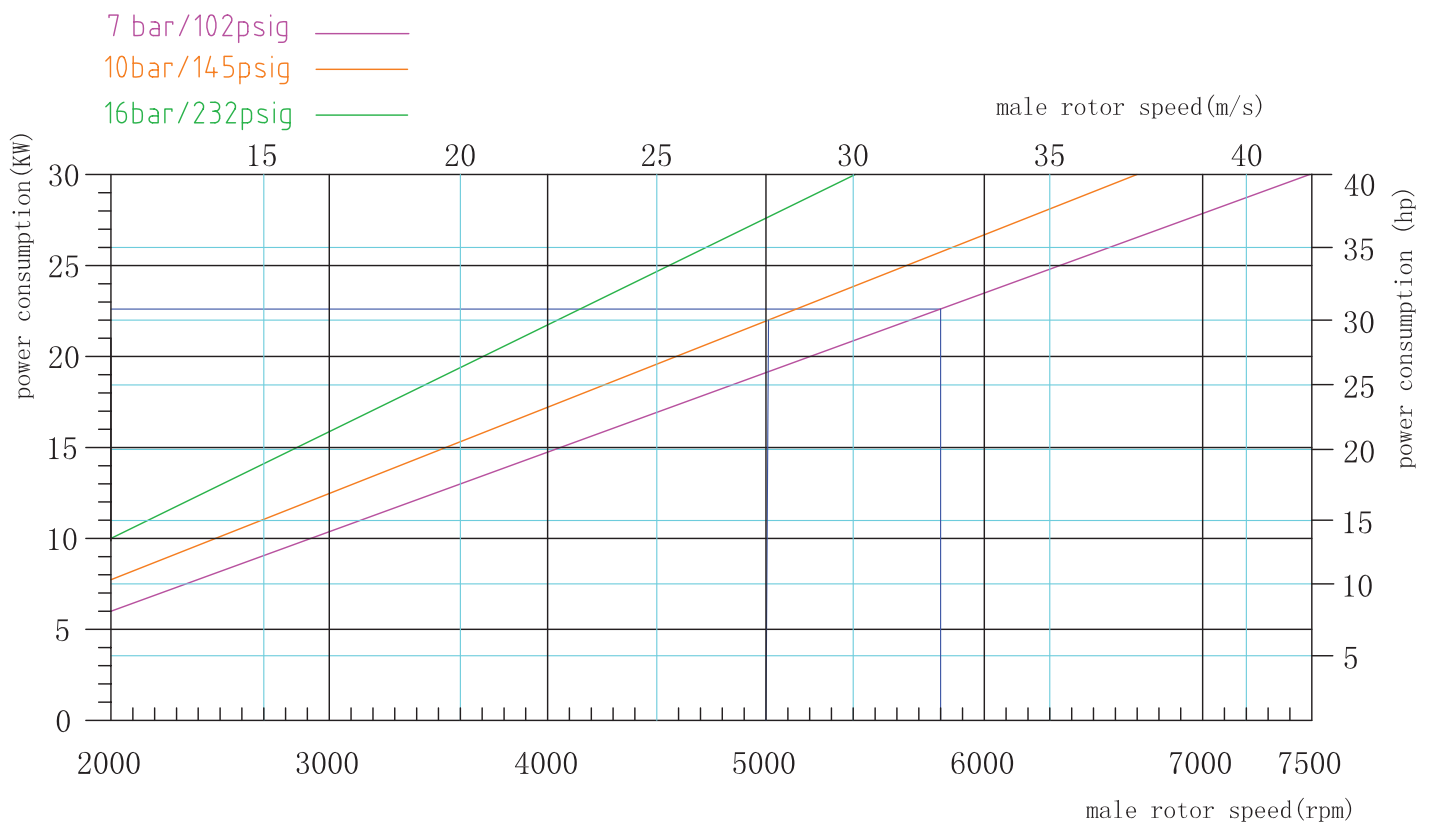
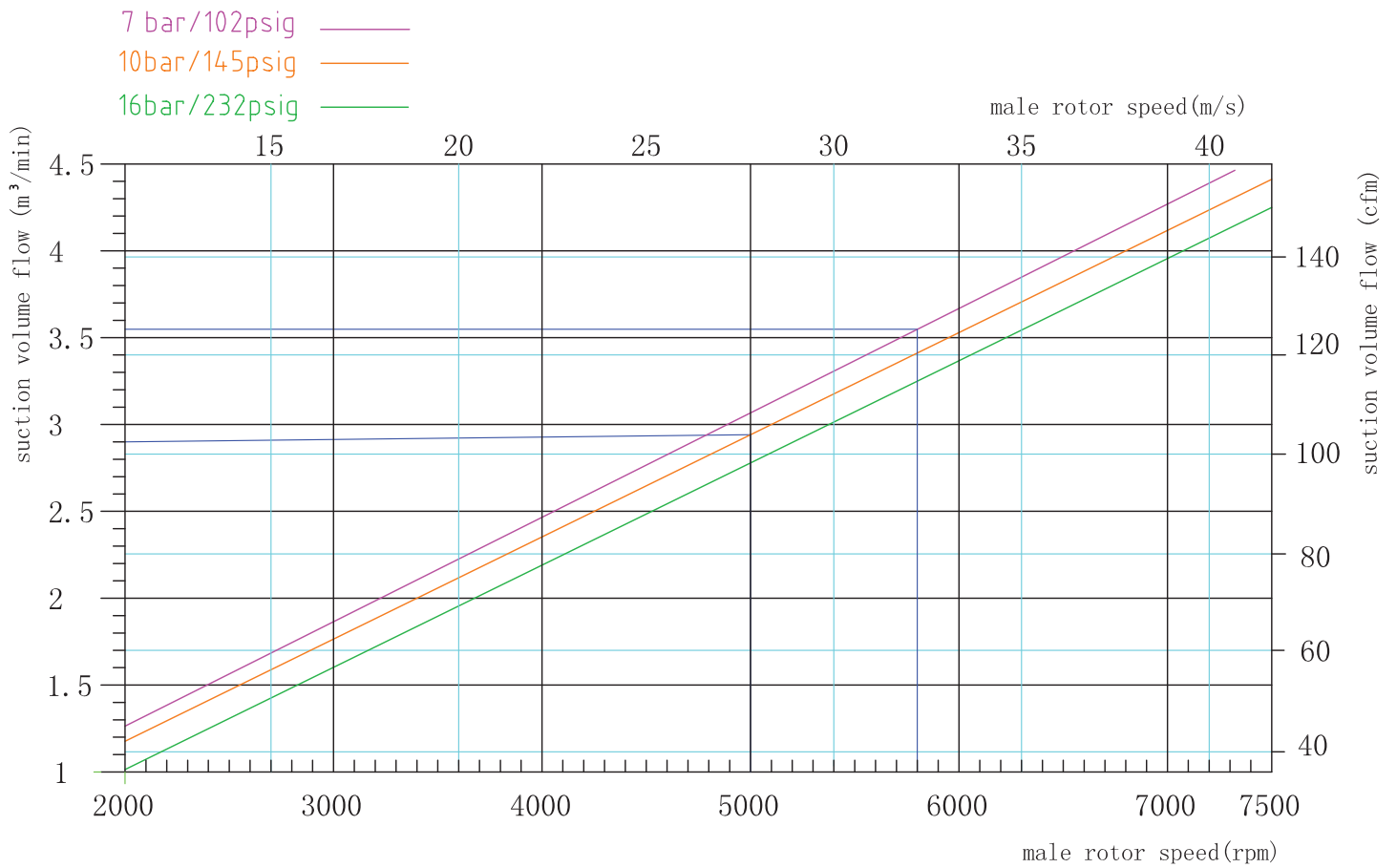

Oil-injected screw air end

# GCU30

Installation drawing [mm]

Weight [kg] 110

